

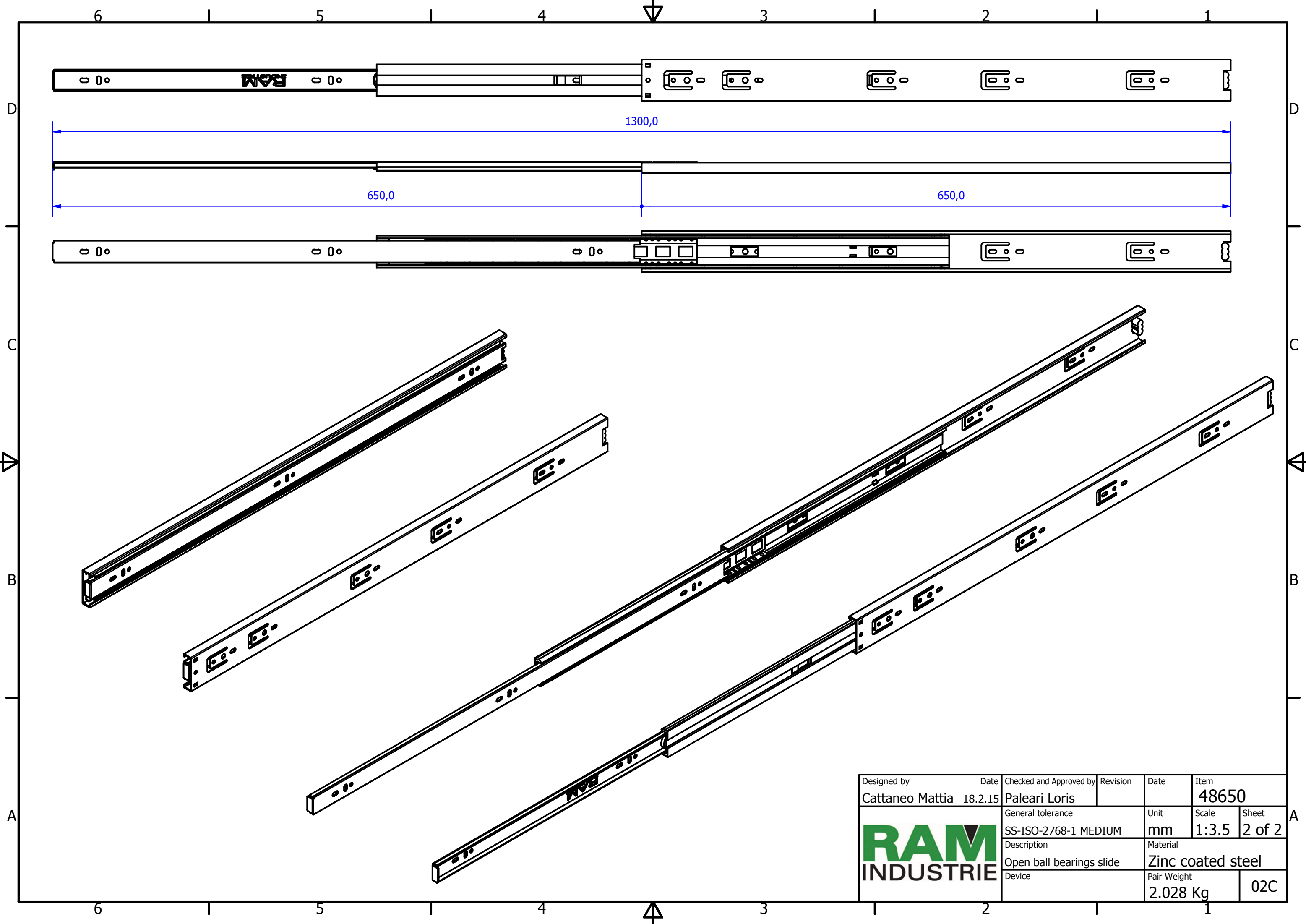

Designed by Cattaneo Mattia	Date 18.2.15	Checked and Approved by Paleari Loris	Revision	Date	Item 48650
		General tolerance SS-ISO-2768-1 MEDIUM	Unit mm	Scale 1:1.75	Sheet 1 of 2
		Description Closed ball bearings slide	Material Zinc coated steel		
		Device	Pair Weight 2.028 Kg	02C	



Designed by Cattaneo Mattia	Date 18.2.15	Checked and Approved by Paleari Loris	Revision	Date	Item 48650
		General tolerance SS-ISO-2768-1 MEDIUM	Unit mm	Scale 1:3.5	Sheet 2 of 2
		Description Open ball bearings slide	Material Zinc coated steel		
Device			Pair Weight 2.028 Kg	02C	