

D (2:1)

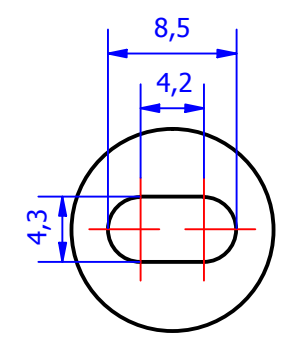

E (2:1)

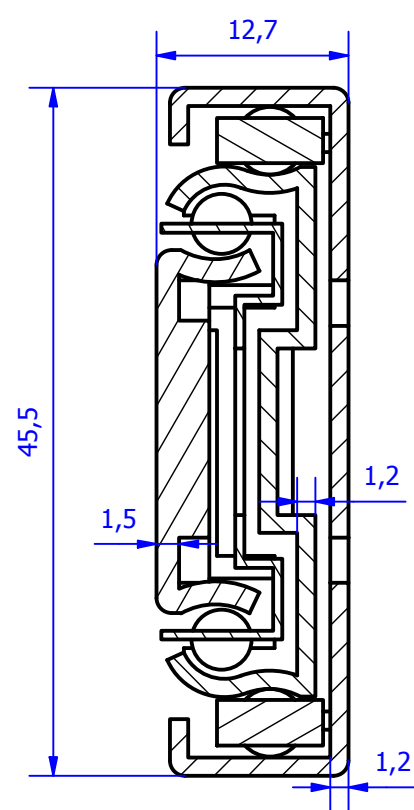

C-C (2:1)

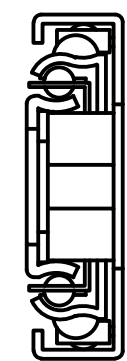

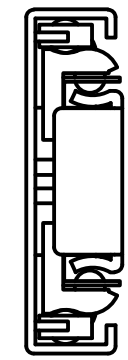

B (1:1)



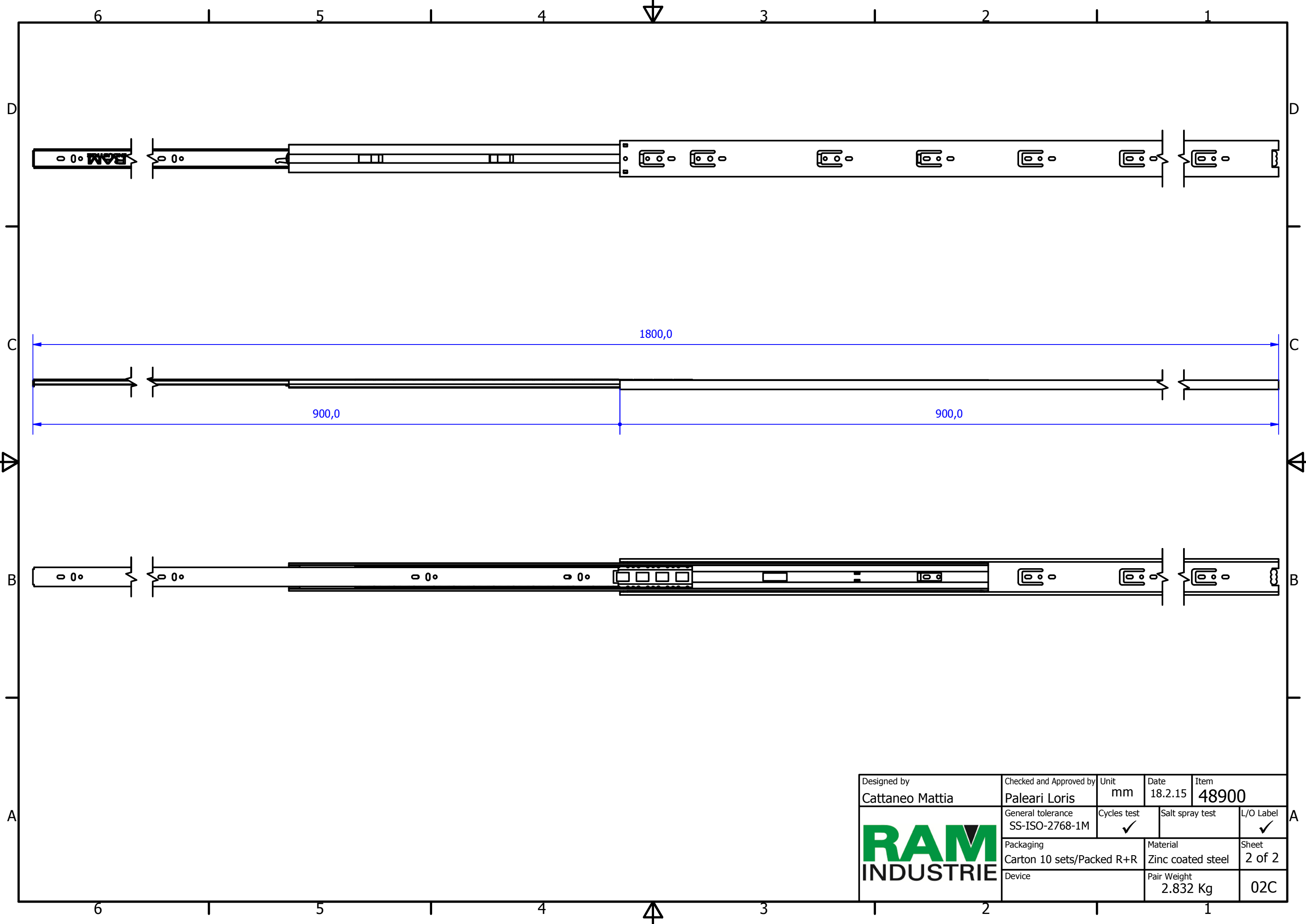

A (1:1)

Designed by Cattaneo Mattia	Checked and Approved by Paleari Loris	Unit mm	Date 18.2.15	Item 48900
		General tolerance SS-ISO-2768-1M	Cycles test ✓	Salt spray test ✓
		Packaging Carton 10 sets/Packed R+R	Material Zinc coated steel	Sheet 1 of 2
Device			Pair Weight 2.832 Kg	02C

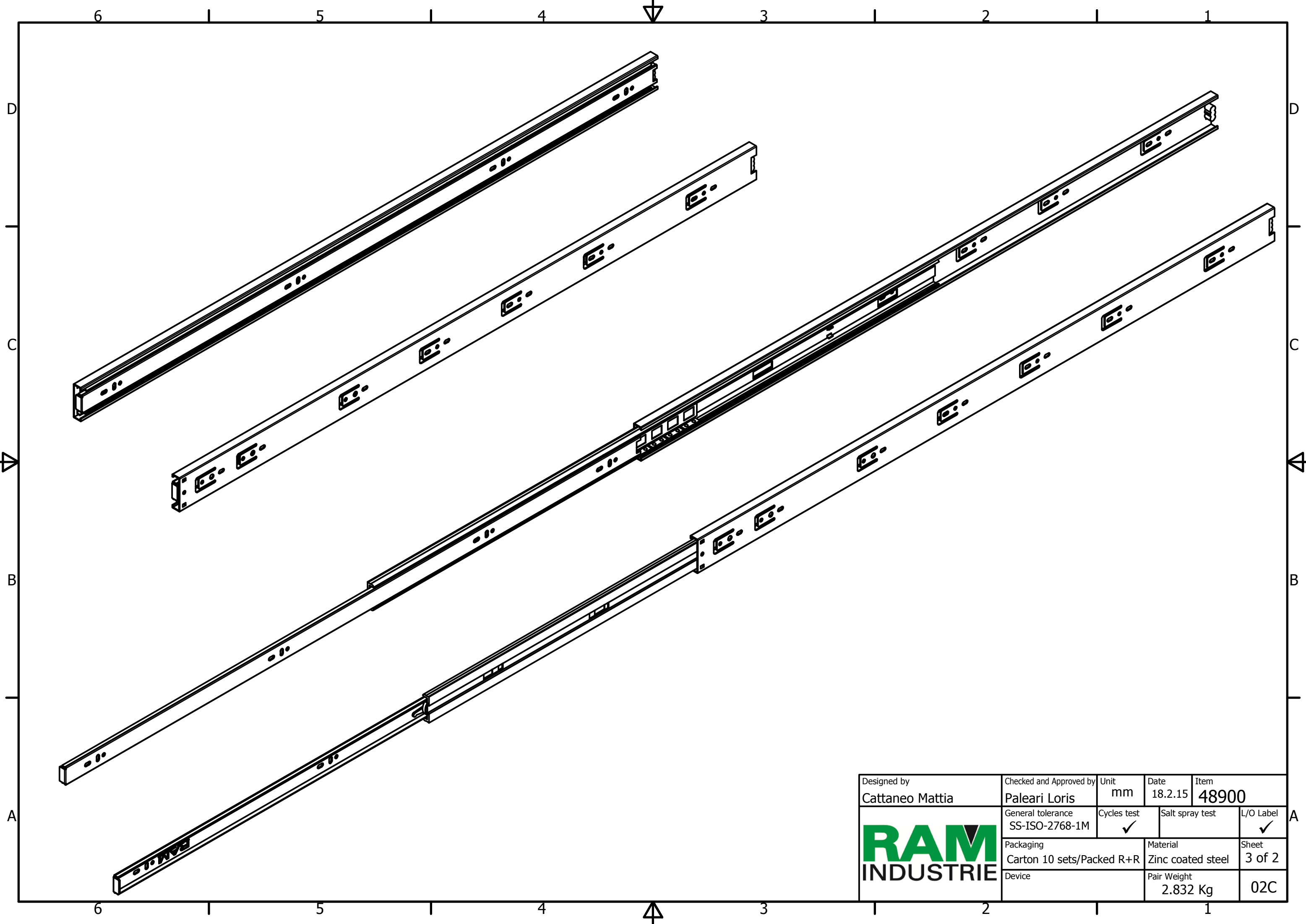

Designed by Cattaneo Mattia	Checked and Approved by Paleari Loris	Unit mm	Date 18.2.15	Item 48900
	General tolerance SS-ISO-2768-1M	Cycles test ✓	Salt spray test	L/O Label ✓
	Packaging Carton 10 sets/Packed R+R	Material Zinc coated steel	Sheet 2 of 2	
	Device	Pair Weight 2.832 Kg	02C	



Designed by Cattaneo Mattia	Checked and Approved by Paleari Loris	Unit mm	Date 18.2.15	Item 48900
	General tolerance SS-ISO-2768-1M	Cycles test ✓	Salt spray test	L/O Label ✓
	Packaging Carton 10 sets/Packed R+R	Material Zinc coated steel	Sheet 3 of 2	
	Device	Pair Weight 2.832 Kg	02C	